



www.FGWilson.com

P800P1/P900E1



Image for illustration purposes only.

Output Ratings

Voltage, Frequency	Prime	Standby
400/230V, 50 Hz	800.0 kVA / 640.0 kW	900.0 kVA / 720.0 kW
480/277 V, 60 Hz	844.0 kVA / 675.2 kW	938.0 kVA / 750.4 kW

Ratings at 0.8 power factor.

Please refer to the output ratings technical data section for specific generator set outputs per voltage.

Prime Rating

These ratings are applicable for supplying continuous electrical power (at variable load) in lieu of commercially purchased power. There is no limitation to the annual hours of operation and this model can supply 10% overload power for 1 hour in 12 hours.

Standby Rating

These ratings are applicable for supplying continuous electrical power (at variable load) in the event of a utility power failure. No overload is permitted on these ratings. The alternator on this model is peak continuous rated (as defined in ISO 8528-3).

Standard Reference Conditions

Note: Standard reference conditions 25°C (77°F) Air Inlet Temp, 100m (328 ft) A.S.L. 30% relative humidity.
Fuel consumption data at full load with diesel fuel with specific gravity of 0.85 and conforming to BS2869: 1998, Class A2.

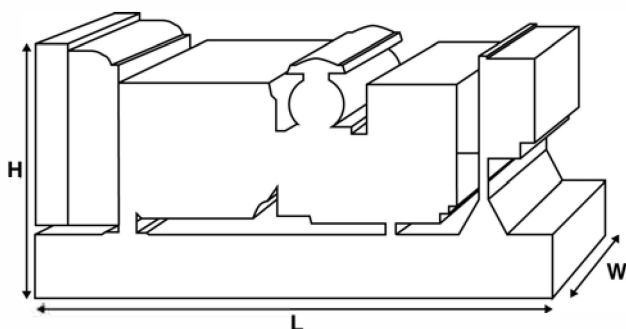

Ratings and Performance Data

Engine Make & Model:	Perkins 4006-23TAG3A	
Alternator manufactured for FG Wilson by:	Leroy Somer	
Alternator Model:	LL7224L	
Control Panel:	PowerWizard 1.1+	
Base Frame:	Heavy Duty Fabricated Steel	
Circuit Breaker Type:	/ 3 Pole ACB/MCCB	
Frequency:	50 Hz	60 Hz
Engine Speed: rpm	1500	1800
Fuel Tank Capacity: litres (US gal)	1494 (394.7)	
Fuel Consumption: l/hr (US gal/hr)		
(100% Load)	- Prime	171.2 (45.2) 198.9 (52.5)
	- Standby	193.4 (51.1) 224.4 (59.3)

Available Options

FG Wilson offer a range of optional features to tailor our generator sets to meet your power needs. Options include:

- Upgrade to CE Certification
- A wide range of Sound Attenuated Enclosures
- A variety of generator set control and synchronising panels
- Additional alarms and shutdowns
- A selection of exhaust silencer noise levels

For further information on all of the standard and optional features accompanying this product please contact your local Dealer or visit: www.FGWilson.com

Dimensions and Weights

Length (L) mm (in)	Width (W) mm (in)	Height (H) mm (in)	Dry kg (lb)	Wet kg (lb)
4280 (168.5)	1690 (66.5)	2379 (93.7)	5875 (12952)	5995 (13217)

Dry = With Lube Oil

Wet = With Lube Oil and Coolant

Ratings in accordance with ISO 8528, ISO 3046, IEC 60034, BS5000 and NEMA MG-1.22. Generator set pictured may include optional accessories.

Engine Technical Data		
No. of Cylinders / Alignment:	6 / In Line	
Cycle:	4 Stroke	
Bore / Stroke: mm (in)	160.0 (6.3)/190.0 (7.5)	
Induction:	Turbocharged Air To Air Charge Cooled	
Cooling Method:	Water	
Governing Type:	Electronic	
Governing Class:	ISO 8528	
Compression Ratio:	13.6:1	
Displacement: l (cu. in)	22.9 (1398.7)	
Moment of Inertia: kg m ² (lb/in ²)	10.61 (36256)	
Engine Electrical System:		
- Voltage / Ground	24/Negative	
- Battery Charger Amps	55	
Weight: kg (lb)	- Dry	2524 (5564)
	- Wet	2663 (5871)

Performance	50 Hz	60 Hz
Engine Speed: rpm	1500	1800
Gross Engine Power: kW (hp)		
- Prime	705.0 (945.0)	759.0 (1018.0)
- Standby	786.0 (1054.0)	839.0 (1125.0)
BMEP: kPa (psi)		
- Prime	2461.0 (356.9)	2208.0 (320.2)
- Standby	2743.0 (397.9)	2440.0 (353.9)

Fuel System				
Fuel Filter Type:	Replaceable Element			
Recommended Fuel:	Class A2 Diesel or BSEN590			
Fuel Consumption: l/hr (US gal/hr)				
	110%	100%	75%	50%
Prime	Load	Load	Load	Load
50 Hz	193.4 (51.1)	171.2 (45.2)	129.7 (34.3)	92.0 (24.3)
60 Hz	224.4 (59.3)	198.9 (52.5)	146.5 (38.7)	100.8 (26.6)
		100%	75%	50%
Standby	Load	Load	Load	Load
50 Hz	193.4 (51.1)	144.8 (38.3)	101.0 (26.7)	
60 Hz	224.4 (59.3)	163.3 (43.1)	110.4 (29.2)	

(Based on diesel fuel with a specific gravity of 0.85 and conforming to BS2869, Class A2)

Air Systems	50 Hz	60 Hz
Air Filter Type:	Replaceable Element	
Combustion Air Flow: m ³ /min (cfm)		
- Prime	69.0 (2437)	76.0 (2684)
- Standby	73.0 (2578)	78.0 (2755)
Max. Combustion Air Intake Restriction: kPa (in H ₂ O)	3.7 (14.9)	3.7 (14.9)

Cooling System	50 Hz	60 Hz
Cooling System Capacity: l (US gal)	106.0 (28.0)	106.0 (28.0)
Water Pump Type:	Centrifugal	
Heat Rejected to Water & Lube Oil:		
kW (Btu/min)	- Prime 280.0 (15923)	309.0 (17573)
	- Standby 310.0 (17629)	330.0 (18767)

Heat Radiation to Room: Heat radiated from engine and alternator		
kW (Btu/min)	- Prime 103.3 (5875)	116.3 (6614)
	- Standby 118.3 (6728)	131.9 (7501)
Radiator Fan Load: kW (hp)	29.9 (40.1)	44.0 (59.0)
Radiator Cooling Airflow: m ³ /min (cfm)	978.0 (34538)	1248.0 (44073)
External Restriction to Cooling Airflow: Pa (in H ₂ O)	250 (1.0)	250 (1.0)

Designed to operate in ambient conditions up to 50°C (122°F).
Contact your local FG Wilson Dealer for power ratings at specific site conditions.

Lubrication System	
Oil Filter Type:	Spin-On, Full Flow
Total Oil Capacity: l (US gal)	123.0 (32.5)
Oil Pan: l (US gal)	113.4 (30.0)
Oil Type:	API CG4 15W-40
Oil Cooling Method:	Water

Exhaust System	50 Hz	60 Hz
Maximum Allowable Back Pressure: kPa (in Hg)	7.0 (2.1)	7.0 (2.1)
Exhaust Gas Flow: m ³ /min (cfm)		
- Prime	193.0 (6816)	209.0 (7381)
- Standby	193.0 (6816)	209.0 (7381)
Exhaust Gas Temperature: °C (°F)		
- Prime	500 (932)	500 (932)
- Standby	500 (932)	500 (932)

Alternator Physical Data	
Manufactured for FG Wilson by:	Leroy Somer
Model:	LL7224L
No. of Bearings:	1
Insulation Class:	H
Winding Pitch Code:	2/3 - 6S
Wires:	6
Ingress Protection Rating:	IP23
Excitation System:	AREP
AVR Model:	R450M

Alternator Operating Data	
Overspeed: rpm	2250
Voltage Regulation: (Steady state)	+/- 0.5%
Wave Form NEMA = TIF:	50
Wave Form IEC = THF:	2.0%
Total Harmonic content LL/LN:	4.0%
Radio Interference:	Suppression is in line with European Standard EN61000-6
Radiant Heat: kW (Btu/min)	
- 50 Hz	39.3 (2235)
- 60 Hz	41.9 (2383)

Alternator Performance Data:	50 Hz			60 Hz		
	415/240V	400/230V	380/220V	480/277V	380/220V	440/254V
Data Item						
Motor Starting Capability* kVA	2268	2117	1924	2507	1620	2134
Short Circuit Capacity** %	300	300	300	300	300	300
Reactances: Per Unit						
Xd	3.090	3.320	3.680	2.921	4.610	3.476
X'd	0.150	0.162	0.180	0.143	0.225	0.170
X''d	0.121	0.130	0.114	0.114	0.180	0.136

Reactances shown are applicable to prime ratings.
 *Based on 30% voltage dip at 0.6 power factor and SHUNT excitation.
 **With optional permanent magnet generator or AREP excitation.

Output Ratings Technical Data 50 Hz				
Voltage	Prime:		Standby:	
	kVA	kW	kVA	kW
415/240V	800.0	640.0	900.0	720.0
400/230V	800.0	640.0	900.0	720.0
380/220V	800.0	640.0	899.0	719.2

Output Ratings Technical Data 60 Hz				
Voltage	Prime:		Standby:	
	kVA	kW	kVA	kW
480/277V	844.0	675.2	938.0	750.4
380/220V	835.0	668.0	913.0	730.4
440/254V	844.0	675.2	938.0	750.4

Documentation

A full set of operation and maintenance manuals and circuit wiring diagrams.

Generator Set Standards

The equipment meets the following standards: BS5000, ISO 8528, ISO 3046, IEC 60034, NEMA MG-1.22.

FG Wilson is a fully accredited ISO 9001 company.

Warranty

All prime equipment carries a one year manufacturer's warranty. Standby equipment, limited to 500 running hours per year, has a two year manufacturer's warranty. For details on warranty cover please contact your local Dealer, or visit our website: FGWilson.com.

Dealer contact details:

FG Wilson manufactures product in the following locations:

Northern Ireland • Brazil • China • India • USA

With headquarters in Northern Ireland, FG Wilson operates through a Global Dealer Network.

To contact your local Sales Office please visit the FG Wilson website at www.FGWilson.com.

FG Wilson is a trading name of Caterpillar (NI) Limited.